

# Repair Guideline Basic master

Art. Nr. 2946.XXXX



## Index

1	General safety instruction: .....	3
1.1	Used symbols.....	3
1.2	Qualification and training .....	3
1.3	Repair works safety instruction.....	3
1.4	Modifications without manufacturer's permission.....	4
1.5	Liability exclusion .....	4
2	Contact and Service address: .....	5
3	Needed tools and utilities .....	5
4	Overview.....	6
4.1	Description / Application area.....	7
4.2	Ambient conditions (in accordance with DIN EN 61010).....	7
4.3	Technical data:.....	7
5	Service Works.....	8
5.1	Removing / attaching a Tank.....	8
5.2	Pressure gauge replacement .....	9
5.3	Filter- pressure regulator unit replacement .....	9
5.4	Tank selector replacement .....	10
5.5	Ballast unit replacement .....	11
5.6	Mixing chamber replacement .....	12
5.7	Cleaning of mixing chamber and nozzles .....	13
5.8	Filter set replacement.....	13
5.9	Blasting hose replacement .....	14
5.10	Glass pane replacement .....	15
6	Final testing .....	16
7	Maintenance recommendation .....	16
7.1	Maintenance table.....	17
8	Spare parts .....	17
8.1	Spare part list for Version A, B and C.....	18
8.2	Spare part drawing – version C .....	19

### **Note!**

**These information are indented for authorized repair companies only. Repair works other than the described in these guidelines are not allowed. In any other case, please contact Renfert in order to coordinate the further procedure.**

## 1 General safety instruction:

This repair guideline contains basic information, which should be observed during the repair of the unit. Therefore, this guideline should be read by the service technician before starting to carry out repair works. Furthermore not only the in the main topic mentioned general safety information have to be observed, also the specific safety instruction in other topics must be observed.

### 1.1 Used symbols

The safety instruction in this guideline must be read and observed necessarily. Additionally different symbols are used.



**Warning notices: read and follow them carefully!**

Warning notices should protect you from danger and will help you to avoid damages of the device.



**Attention: danger of life caused by electric shock!**

When you see this sign, you should always check for the appliance for being voltage free and being protected against enabling by mistake.

Caution!

The Caution! box denotes a hazard. It calls attention to a procedure, practice, or the like, which, if not correctly performed or adhered to, could result in personal injury. Do not proceed beyond a caution box until the indicated conditions are fully understood and met.

Safety instructions, which are located direct at the unit, must be observed necessarily.

### 1.2 Qualification and training

Personnel performing repair and maintenance works described in this guideline shall meet the corresponding requirements. Otherwise, the personnel have to be trained prior to performing repair and maintenance works to ensure that the personnel understand the information in these guidelines completely.

### 1.3 Repair works safety instruction

The Basic master is an electrical device with inherent hazard potential. This device may only be installed and operated by authorized specialists after examination of

compliance with locally applicable standards. The following safety instruction must be strictly observed during operation and maintenance works.

- Prior to commissioning, compare the information on the nameplate with the specifications of the local mains power network and the connection values for compressed air.
- Always disconnect the unit from the compressed air supply prior to performing any maintenance tasks.
- Never operate a sandblaster without a suitable dust extraction unit or suitable personal protective clothing, as this can be detrimental to your health. The type of dust extractor must relate to the type of dust produced by your sandblasting work. It is imperative to adhere to the legal regulations (in Europe this means EN 60335-2-69).
- When working on the tank (filling up, cleaning, maintenance) wear protective glasses for protecting your eyes.
- Any residue of abrasive material on the gasket may lead to leakage and early wear of the gasket. After filling up clean the thread and the gasket and close the lid properly.
- Solvents and tensides can create micro cracking in the plastic (danger of explosion!). Clean the tank and the lid only with a dry cloth. Do not write or stick something on the tanks.
- Check the tanks and the lids regularly on damages and replace them in case of doubt.
- Check the tank cover for correct seating prior to beginning operation. Covers that are not securely closed can suddenly be blown off as the tank pressure increases. The resulting flying parts and abrasive represent a serious hazard.
- Improper use can result in the risk of eye or skin injuries.
- Never direct the nozzles towards your eyes or uncovered areas of skin!
- Never work with the view screen open!



Caution!

Always wear appropriate eye protection when operating the unit! Failure to wear eye protection can result in eye injuries due to airborne particles.

- Do not employ the foot switch when only compressed air supply hose is connected. The loose hose could wrap around itself and cause serious injury.
- Always disconnect the unit from the mains power supply prior to replacing the fluorescent tube.
- Never press on or bend the lamp body during replacement (breakage risk). If necessary, wear gloves or use a cloth.
- Regularly inspect all connecting lines and hoses (e.g., power cord and compressed air hoses) for damage (e.g., kinks, cracks, porosity). The unit may not be operated if the power cord is damaged.

## 1.4 Modifications without manufacturer's permission

Modifications of the unit, other than described in the user manual are only allowed after getting permission from Renfert. Original spare parts are important for the equipment safety. The use of other than original spare parts is not allowed.

## 1.5 Liability exclusion

Renfert GmbH shall be absolved from all claims for damages or warranty if:

- The product is employed for any purposes other than those cited in the operating instructions;
- The product is altered in any way other than those alterations described in the operating instructions;
- The product is repaired by other than an authorized facility or if any but Renfert OEM parts are employed;
- The product continues to be employed, despite obvious safety faults or damage;
- The product is subjected to mechanical impacts or is dropped.

## 2 Contact and Service address:

If you have question regarding the use of in case of service please contact the following address:

Renfert GmbH  
Industriegebiet  
78247 Hilzingen  
Germany

Phone: ++49 (07731) 8208-0  
Fax: ++49 (07731) 8208-70

Mail: [info@renfert.com](mailto:info@renfert.com)  
Internet: [www.renfert.com](http://www.renfert.com)

Customers in the USA, Canada and Mexico please contact

Renfert USA Inc.  
3718 Illinois Avenue  
St. Charles, Illinois 60174  
U.S.A

Phone: ++1 630 762-1803  
Toll free: 1 800 336-7422  
Fax: ++1 630 762 9787

Internet: [www.renfertusa.com](http://www.renfertusa.com)

## 3 Needed tools and utilities

- Set of Allen keys
- Set of screwdrivers (slotted and Phillips style)
- Set of box/open-end wrenches (metric)
- Loctite 638 Metal glue
- Loctite 242 retaining compound
- Torque wrench (not essential)
- Face Spanner, size 7-40 (Renfert Art. Nr. 33254)
- Set of pliers

## 4 Overview

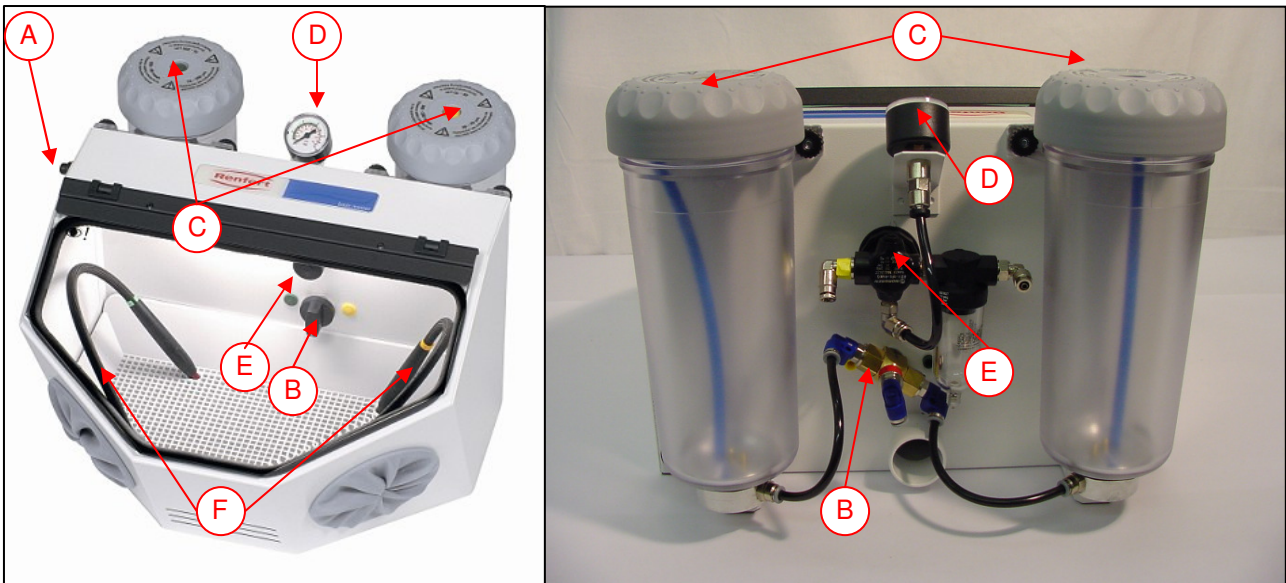

Fig.1 - Overview

Pos.	Description
A	On/off switch for lighting
B	Tank selector
C	Abrasive tank
D	Pressure gauge
E	Filter - pressure regulator
F	Blasting hose with handle

## 4.1 Description / Application area

The Basic master units are designed for use in dental laboratories to remove investment residues, oxides on cast objects, and for surface treatment.



Caution!

The Basic master is 230V~ or 120V~ operated. Internal parts of the unit can carry high voltage. Before starting service works, always remove the mains plug

## 4.2 Ambient conditions (in accordance with DIN EN 61010)

The unit may only be operated:

- Indoors;
- Up to an altitude of 2,000 m [6,500 ft] above level;
- At an ambient temperature range of 5 – 40 [41 - 104°F];
- At a maximum relative humidity of 80% at [87.8°F], dropping linearly to 50% relative humidity at 40°C [104°F];
- With a mains power supply whose voltage fluctuations do not exceed 10% of the rated value;
- Under contamination level 2 conditions;
- Under over-voltage category II conditions.

## 4.3 Technical data:

Voltage:	230-240 V / 50/60 Hz 90-120 V / 50/60 Hz
Power consumption Lamp:	11W
Overall power consumption:	12,3 W (230 V) 9 W (120 V)
Working pressure:	1 - 6 bar [14,5 - 87 psi]
Connecting pressure:	6 - 8 bar [87 - 116 psi]
Air consumption:	120 l/min. at 6 bar [87 psi]
Blasting chamber volume:	18 l
Tank capacity:	1000 ml each
Ø hose connection pressured air:	inner: 4 mm [0,16 inch] outer: 6 mm [0,24 inch]
Ø Size of connection point for external extraction unit	inner: 35 mm [1,38 inch] outer: 40 mm [1,58 inch]
Dimensions (WxHxB) (4 Tank version)	400 x 285 x 400 mm [15,76 x 11,23 x 15,76 inch]
Weight 2 tank version (empty):	approx. 7 kg
Cable length:	2 m [78,74 inch]
Noise level according to DIN 45635-01-KL3	Lp(A) <72dB(A)

## 5 Service Works



Caution!

Generally acknowledged technical rules for safe and correct working must be observed.

### 5.1 Removing / attaching a Tank

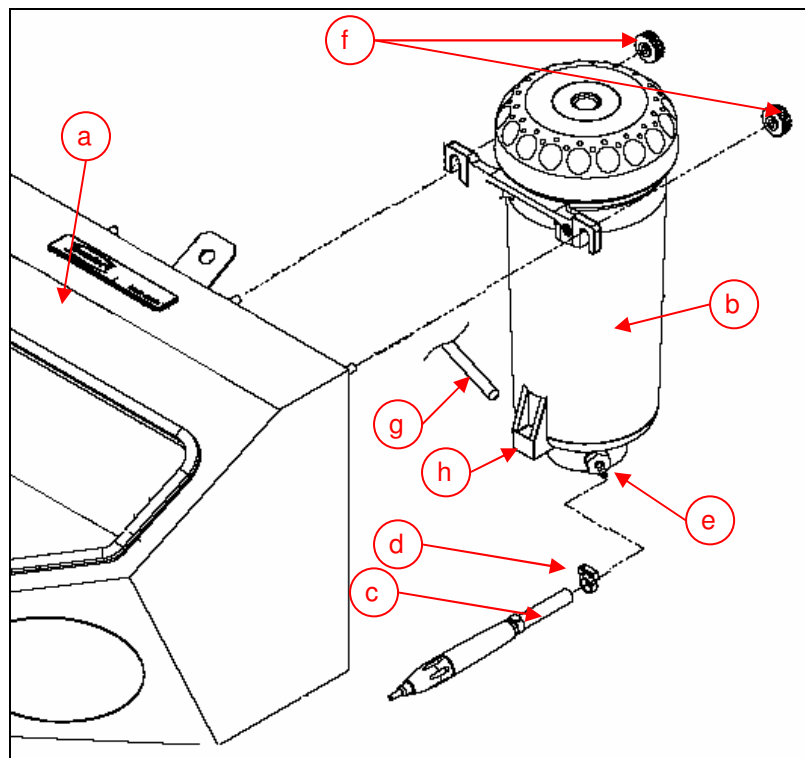

Fig. 2 - Tank and body

- Switch-off the unit.
- Disconnect from mains supply.
- Disconnect from pressured air supply.
- Loosen the knurled nuts (fig. 2 f).
- Hang out the tank (fig. 2 b) at the body (fig. 2 a).
- Pull the pressured air hose (fig 2 g) out of the push-in connector at the tank.
- Remove the blasting hose (fig. 2 c) by opening the hose clamp (fig. 2 d) and pulling it from the hose nozzle (fig. 2 e).
- After the repair, put the blasting hose back to the hose nozzle and fasten it with the hose clamp.
- Push the pressured air hose completely into the push-in connector.
- Restore the tank at the body and fasten the knurled nuts (fig. 2 f).
- Take care that the tank retaining collar (fig 2 h) is hung in at the body correctly.



## 5.2 Pressure gauge replacement

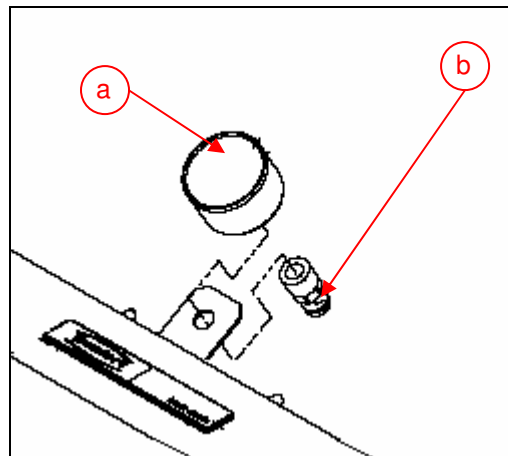

Fig. 3 - Pressure gauge

- Pull the pressured air hose out of the push-in connector (fig. 3 b) at the pressure gauge.
- Remove the push-in connector and take the pressure gauge out of the body.
- Insert the new pressure gauge into the body. Take care that the pressure gauge is mounted even.
- Fasten the push in connector (fig. 3 b) at the gauge.
- Lock the push-in connector thread with Loctite 242 retaining compound.
- Push the pressured air hose into the push-in connector completely.

## 5.3 Filter- pressure regulator unit replacement

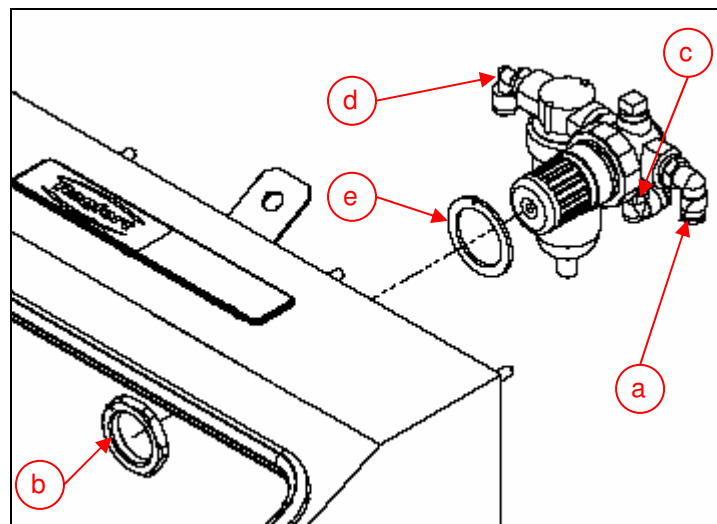

Fig. 4 - Filter - pressure regulator

- Disconnect the unit from pressured air supply by removing the supply hose at the hose connector (fig. 4 d).
- Pull the pressured air hose (for the foot switch) out of the push-in connector (fig.4 a).
- Pull the pressured air hose (for the foot pressure gauge) out of the push-in connector (fig.4 c).
- Unscrew the retaining nut of the filter pressure regulator unit (fig 4 b) and remove the regulator unit (fig. 4 a) unit to the rear side of the body.

- Install the new pressure regulator (fig. 4 a) together with the rubber sealing (fig 4 e) from the rear side of the body and attach it with the nut (fig. 4 b).
- Mark the bended hose nozzle (fig. 4 a) with a yellow adhesive tape.
- Push the pressured air hose (to the pressure gauge) into the push-in connectors (fig. 4 c) completely.

## 5.4 Tank selector replacement

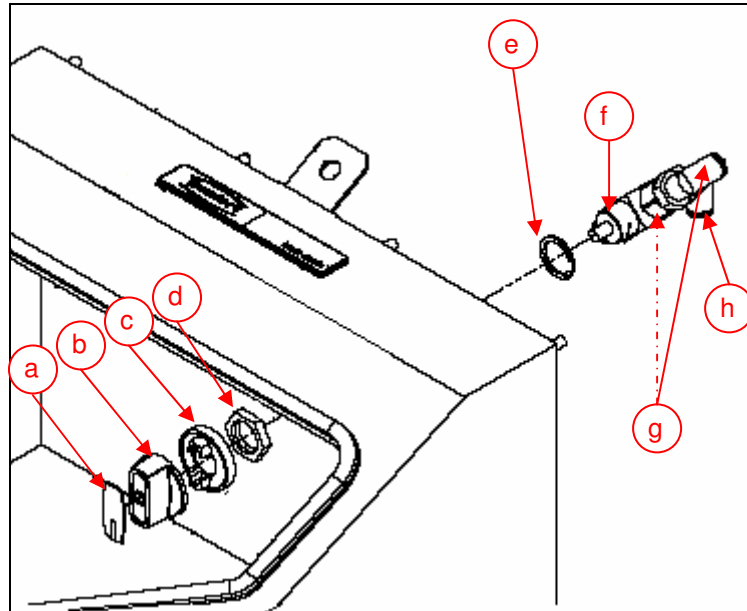

Fig. 5 - Tank selector

- Disconnect the unit from pressured air supply
- Pull the pressured air hose (for the foot switch) out of the push-in connector (fig. 5 h)
- Set the tank selector knob downwards.
- Pull off the cap (fig. 5 a) from the selector knob (fig. 5b).
- Loosen the fixation nut of the knob (fig. 5 b) and take off the knob and the nut cover (fig. 5 c).
- Remove the nut (fig. 5 d) from the ball valve.
- Pull the pressured air hoses out of the push-in connectors (fig. 5 g) of the ball valve and take the tank selector out of the body.
- Insert the new tank selector (fig. 5 f) together with the aluminum sealing ring (fig. 5 e) into the body and fasten it with the nut (fig. 5 d) (Alignment 45° rotated (see fig. 1 b right)
- Push the pressured air hose into the push-in connectors (fig. 5 g) completely.
- Mark the bended push-in connector (fig. 5 h) with a red adhesive tape.
- Now add the nut cover (fig. 5 c) and the knob (fig. 5 b). Fasten the knob with his fixation nut in “down” position.
- Clip the knob cap (fig. 5 a) onto the knob.

## 5.5 Ballast unit replacement



Caution!



Generally acknowledged technical rules for safe and correct working at electrical components must be observed.

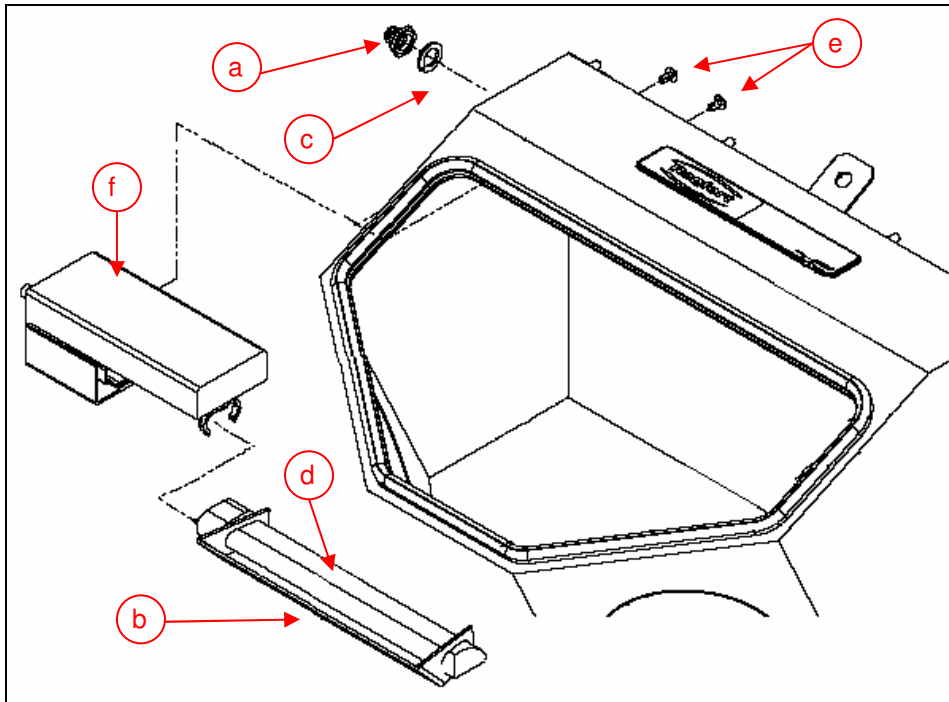

Fig. 6 - Ballast unit and fluorescent tube

- Switch-off the unit.
- Disconnect from mains supply.
- Remove the cap of the on/off switch (fig. 6 a) by unthreading it and remove the felt ring (fig. 6 c).
- Pull the fluorescent tube (fig. 6 d) carefully out of his socket.
- Remove the left tank according to 5.1.
- Remove the screws (fig.6 e) and take the ballast unit (fig. 6 f) out of the body
- Install the new ballast unit in the body and mount it with the 2 screws (fig. 6 e).
- Take care that the sealing between the ballast unit and the body fits perfect.
- Attach the felt ring (fig 6 c) and the cap (fig. 6 a) to the on/off switch.
- Change the lamp cover (fig 6 b) from old to new tube.
- Plug the florescent tube into the socket at the ballast unit carefully.
- Mount the tank according to 5.1.

Caution!

Please use only Renfert original replacement fluorescent tube sets (no. 92900-0002), Osram Dulux S/E 11W / 21-840, Philips PL-S 11W / 840 / 4P, or Sylvania CF-S 11W / 840 / fluorescent tubes.

## 5.6 Mixing chamber replacement

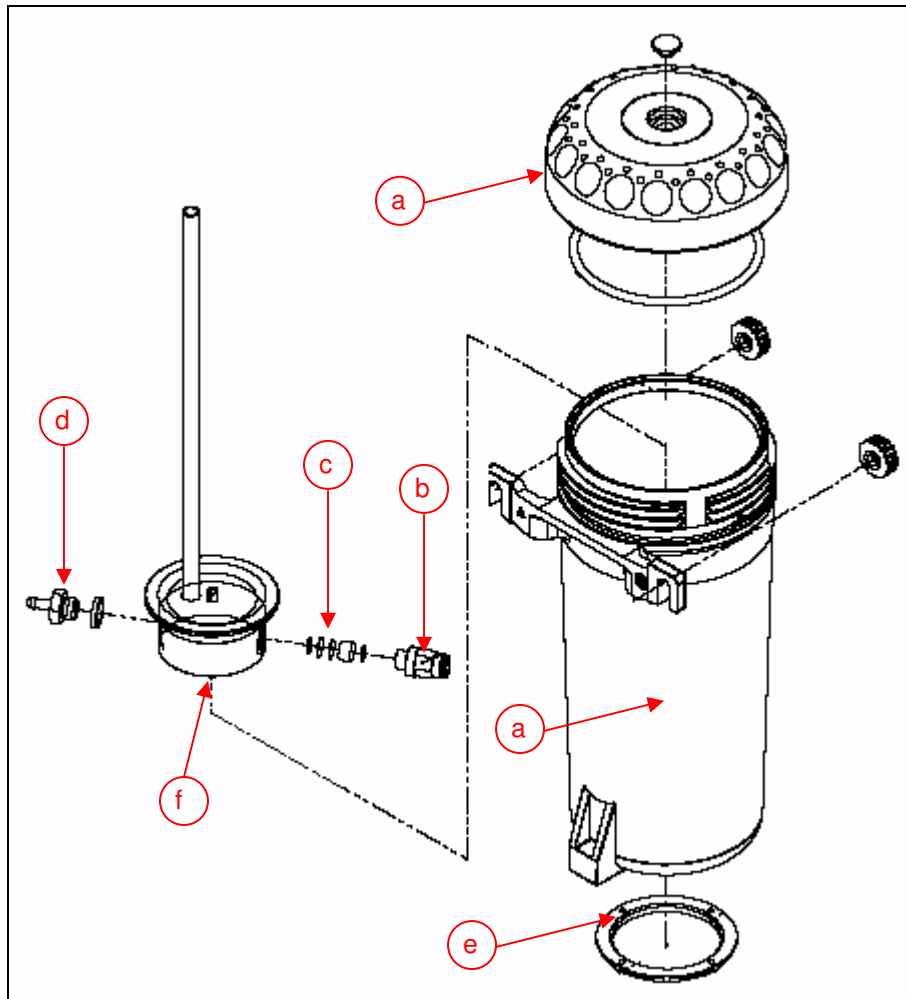

Fig. - 7 Tank

- Disconnect the unit from pressured air supply.
- Remove tank according point 5.1.
- Unscrew tank cap (fig. 7 a).
- Unscrew the push-in connector (fig. 7 b) and remove the filter set (fig. 7 c).
- Remove the hose nozzle (fig 7 d) together with the sealing ring.
- Remove the nut (fig. 7 e) with the face spanner and remove the mixing chamber from the tank shell.
- Turn the new mixing chamber upside down and lay the O-ring into the groove of the mixing chamber.
- Put the tank shell (fig. 7 g) over the mixing chamber and attach it with the nut (fig. 7 e).
- Take care that the O-ring is in the right position.
- Attach the hose nozzle (fig 7 d) together with the sealing ring.
- Install the filter set (fig.7 c) in the correct way (See 5.8).
- Mount the push-in connector (fig. 7 b).
- Mount the tank according to 5.1.

## 5.7 Cleaning of mixing chamber and nozzles

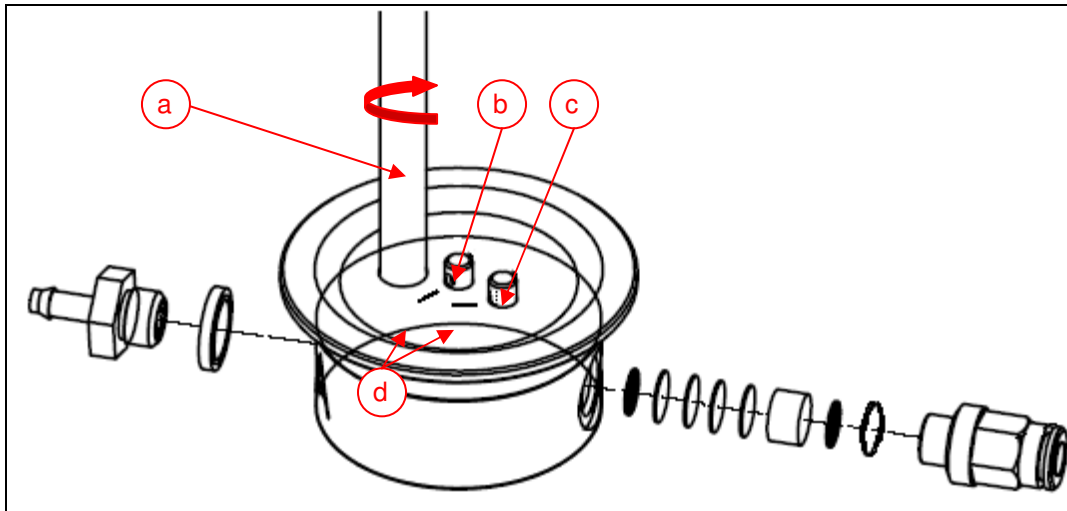

Fig. 8 - mixing chamber

- Disconnect the unit from pressured air supply.
- Remove tank according point 5.1.
- Remove the mixing chamber according to 5.6.
- Unscrew the standpipe (fig 8 a) from the mixing chamber.
- Remove the nozzle (fig 8 b) with a universal pliers.
- If this is not possible, you can clamp the nozzle in a bench vice carefully and turn the complete mixing chamber in order to pull out the nozzle.
- At 25-70µm Tank, remove also the whirl nozzle (fig. 8 c).
- Clean both nozzles and the complete mixing chamber carefully. Push a thin wire through the nozzles in order to remove deposits.
- Remove the filter inside the whirl nozzle (fig. 8 c) and clean it. Put it back afterwards.
- Glue the nozzles into the mixing chamber with Loctite 638 metal glue. Use only a very small amount of glue.
- The direction of the nozzle holes is marked on the mixing chamber.
- Screw the standpipe (fig 8 a) into the mixing chamber.
- Assemble the tank according to 5.6.
- Mount the tank according to 5.1.

## 5.8 Filter set replacement

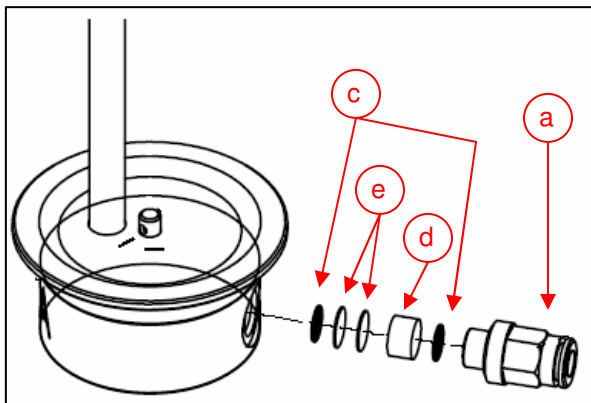

Fig. 9 - Filter in Tank 70 – 250 µm

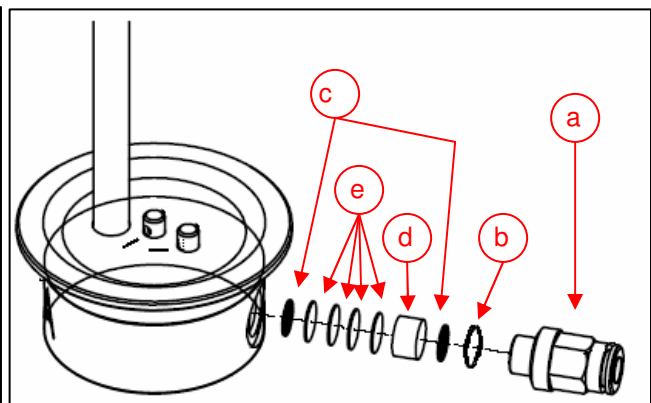

Fig. 10 - Filter in Tank 25 – 70 µm

- Disconnect the unit from pressured air supply.
- Pull out the pressured air hoses from the push-in connectors (fig. 9 and 10 a).
- Unscrew the push in connector (fig. 9 and 10 a) from the mixing chamber.
- Remove the filter set (fig. 9+10 b, c, d, e).
- Clean the mixing chamber with pressured air or according to 5.7.
- Install the new filter set.
- First, lay a steel sieve (fig. 9 +10 c) into the mixing chamber.
- Then add 4 (25-70 $\mu$ m Tank) respectively 2 (70-250 $\mu$ m Tank) fine fleece filter (fig 9+10 e). The yellow marked side faces to the center of the mixing chamber
- Now add 1 rough textured filter (fig. 9+10 d).
- Finally, ad another steel sieve (fig. 9+10 c).
- Press the complete filter set into the mixing chamber.
- Add an O-Ring (fig 10 b) at 25-70 $\mu$ m Tank only.
- Screw the push in connector (fig. 9 and 10 a) into the mixing chamber.
- Push the pressured air hoses into the push-in connectors (fig. 9 and 10 a).

## 5.9 Blasting hose replacement

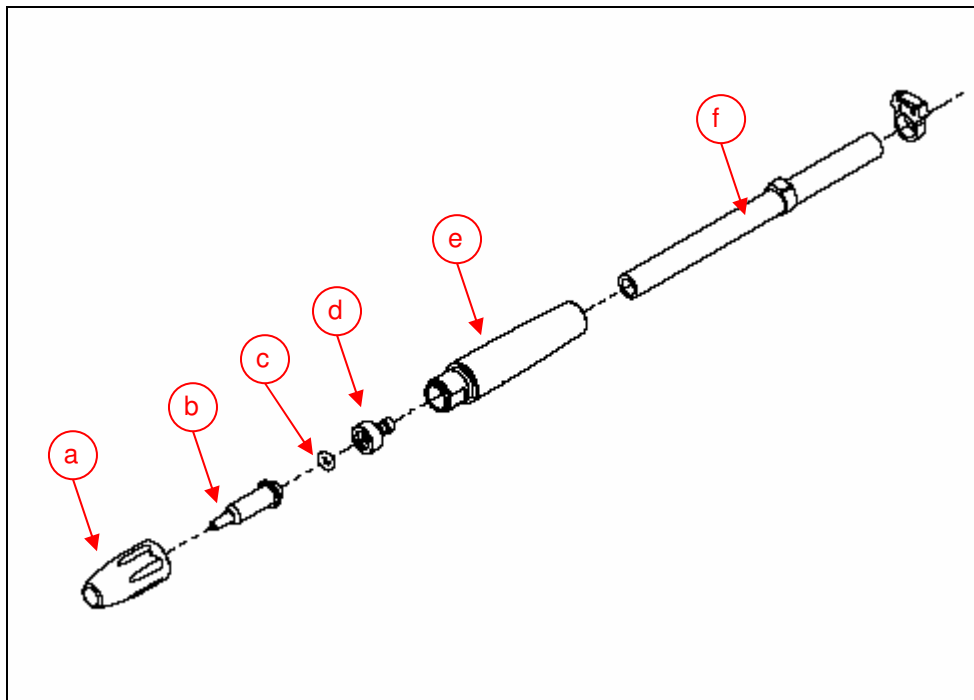

Fig. 11 – Blasting hose

- It is possible to dismantle the blasting hose completely.
- Detach the blasting hose from the tank according to 5.1.
- To change the blasting nozzle unscrew the cap nut (fig 11 a).
- Take care that the O-Ring (fig 11 c) is at the correct position during the installation of the new nozzle.
- In order to change the hose, push the handle (fig. 11 e) backwards a few cm. and pull out the hose stem (fig. 11 d).
- Complete the blasting hose in reverse order.
- Attach the blasting hose at the tank again according to 5.1.

## 5.10 Glass pane replacement

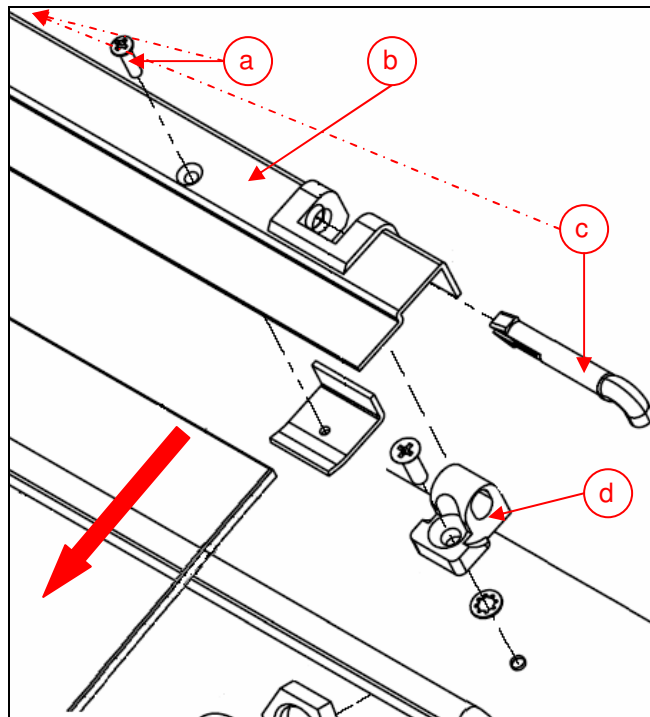

Fig. 12 - glass pane and hinge

- Open the 2 screws (fig 12 a) and pull the glass pane to the front out of the glass pane holder (fig. 13 b).
- Insert new glass pane into the holder and clamp the pane with the 2 screws (fig. 12 a), Torque = 45 Ncm.
- Take care that the glass pane is installed in the center of the holder.
- If you want to remove the holder, pull the retaining bolt (fig. 12 c) out of the hinge block (fig. 12 d).
- During the mounting of the glass pane holder, take care that the hinges are smooth running. If not, tilt the hinge block a little bit.
- The coated side of the glass pane has to face down.



Caution!

Never use the unit without glass pane.

## 6 Final testing

All below mentioned checks have to be performed after repair and maintenance works. For this, the unit has to be connected to the mains and pressured air supply and has to be ready to use according the user manual (without abrasive).

- Adjust pressure to 6 bar at the maintenance unit.
- Check the tank cover for correct seating.
- Select first tank.
- Activate the foot switch.
- Check all hose connectors and tank parts for leakage.
- Now select second tank and repeat the test.
- Switch on and off the lamp several times  
Lamp should start immediately
- Disconnect the unit from pressured air supply.
- Insert suitable abrasive into the tank and close tank cover.
- Perform a function test. The abrasive should leave the nozzle continuously.  
Perform this test for several minutes for each tank.
- Electrical tests must be performed in accordance with national regulations (e.g. in Germany according to DIN VDE 0701 Part 1 and Part 3)



**If one or more tests failed, ensure that the error will be eliminated before forwarding the unit to the customer. Repeat the complete final test after eliminating the error.**

## 7 Maintenance recommendation

- A scheduled periodic maintenance will increase the lifetime of the Basic master so that the costs for maintenance are a wise investment. Timely identification and elimination of defects will protect you from consequential damage.
- Renfert has created a maintenance table, which will ensure the reliability and cost effectiveness of your unit.



## 7.1 Maintenance table

Work	Note	Needed parts
Cleaning of the housing	Use only solvent-free cleansers (e.g., soapy water).	lint-free cloth, soap
Condensed water.	Occasionally check whether water has formed in the maintenance unit. If so, press the drainage valve on the filter pressure reducer unit.	-
Blasting nozzle	If necessary, change the blasting. See chapter 5.9.	Blasting nozzle
Change of the glass pane	If necessary, change the glass pane. See chapter 5.10	New glass pane, screwdriver
Change of blasting hose	The blasting hoses are prone to natural wear and tear and must therefore, occasionally be replaced. See chapter 5.9	New blasting hose, pliers
Change of fluorescent lamp	Remove the dust and sand from lamp socket. See chapter 5.5	New lamp,
Filter set replacement	Due to oily or humid air, the filters can clog. See chapter 5.8	New filter set, tools

## 8 Spare parts

### Version:

Due to permanent quality improvement, some parts are subject to change. This causes a change of the spare part list. The spare part lists are marked with different letters. For this unit the versions A, B, and C are available. The version is indicated on the type plate in front of the serial number.

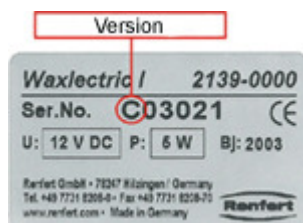

Spare part lists and line drawings for other versions are available at [www.renfert.com](http://www.renfert.com).

## 8.1 Spare part list for Version A, B and C

Art. Nr.	Description	POS	Index	Version A	Version B	Version C	For repair workshop recommended parts
900028889	Filter set for all BASIC 25-70 µm	5	a	✓	✓	✓	X
900028888	Filter set for all BASIC 70-500 µm	5	b	✓	✓	✓	X
33035	O-Ring DIN 3771 82x4 NB 55	6		✓	✓	✓	X
929000001	IT Handpiece 25-500 µm	8	a	✓	✓	✓	X
900033199	IT Hose stem 25-70 µm	8	b	✓	✓	✓	X
929000053	Threaded joint complete, IT 25-70 µm.	8	c	✓	✓	✓	X
929000052	IT Blasting hose f. K4 25µ/BASIC 25-70	8	d	✓	✓	✓	X
900033194	IT Hose stem 70-500 µm	9	b	✓	✓	✓	X
929000503	Threaded joint complete, IT 70-500 µm	9	c	✓	✓	✓	X
929000502	IT Blast. hose K4 50-500µ/BASIC 70-500m	9	d	✓	✓	✓	X
900033196	O-Ring DIN 3771 3x2 NBR 70	10		✓	✓	✓	X
929000002	Fluorescent tube Set 11W / 2G7	11		✓	✓	✓	(X)
929000007	Fluoresce. lamp ballast 230-240V/11W/2G7	12	a	✓	✓	✓	(X)
929000005	Connection cable 230/240	12	b	✓	✓	✓	
929000008	fluorescent lamp ballast 90-120V/11W/2G7	13	a	✓	✓	✓	(X)
929000006	Connection cable 90-120 V	13	b	✓	✓	✓	(X)
900034103	Hinge complete 2946 / 2960	14		✓	✓	✓	
900033005	Locking devices with screws	14	a	✓	✓	✓	
900021316	Glass pane 2946 / 2960	15		✓	✓	✓	X
900035756	Glass pane uncoated Master	15	a	✓	✓	✓	
21120	3-way switch complete	16		✓	✓	✓	X
929460001	Pressure regulator and maintenance unit 2946	17		✓	✓	✓	X
21119	Manometer with screw fitting	18		✓	✓	✓	X
29310000	Pneumatic foot switch	19		✓	✓	✓	X
32729	PVC edge protection	20		✓	✓	✓	
900034101	Grate 2946	21		✓	✓	✓	
900034111	Fixation for blasting hose 2946	22		✓	✓	✓	
900034104	Ventilating flap 2946	23		✓	✓	✓	
30923	Handcuff ring - slit	24	a	✓	✓	✓	
900030135	Cuffs for all Microblasters (pair of)	24	b	✓	✓	✓	X
21264	Hardware BASIC	25		✓	✓	✓	
900021368	Spare tank 25-70µ basic left	26		✓	✓	✓	
21110	Mixing Chambers for BASIC 25-70 µm µ	26	a	✓	✓	✓	X
900021369	Spare tank 25-70µ basic right	27		✓	✓	✓	
900021370	Spare tank 70-250µ basic left	28		✓	✓	✓	
21111	Mixing Chamber for BASIC, 70-250 µm	28	a	✓	✓	✓	X
900021371	Spare tank 70-250µ basic right	29		✓	✓	✓	
929035801	Tank shell with cover new basic	30		✓	✓	✓	
900035801	Spare Tank cover basic 25-500µ	30	a			✓	

## 8.2 Spare part drawing – version C

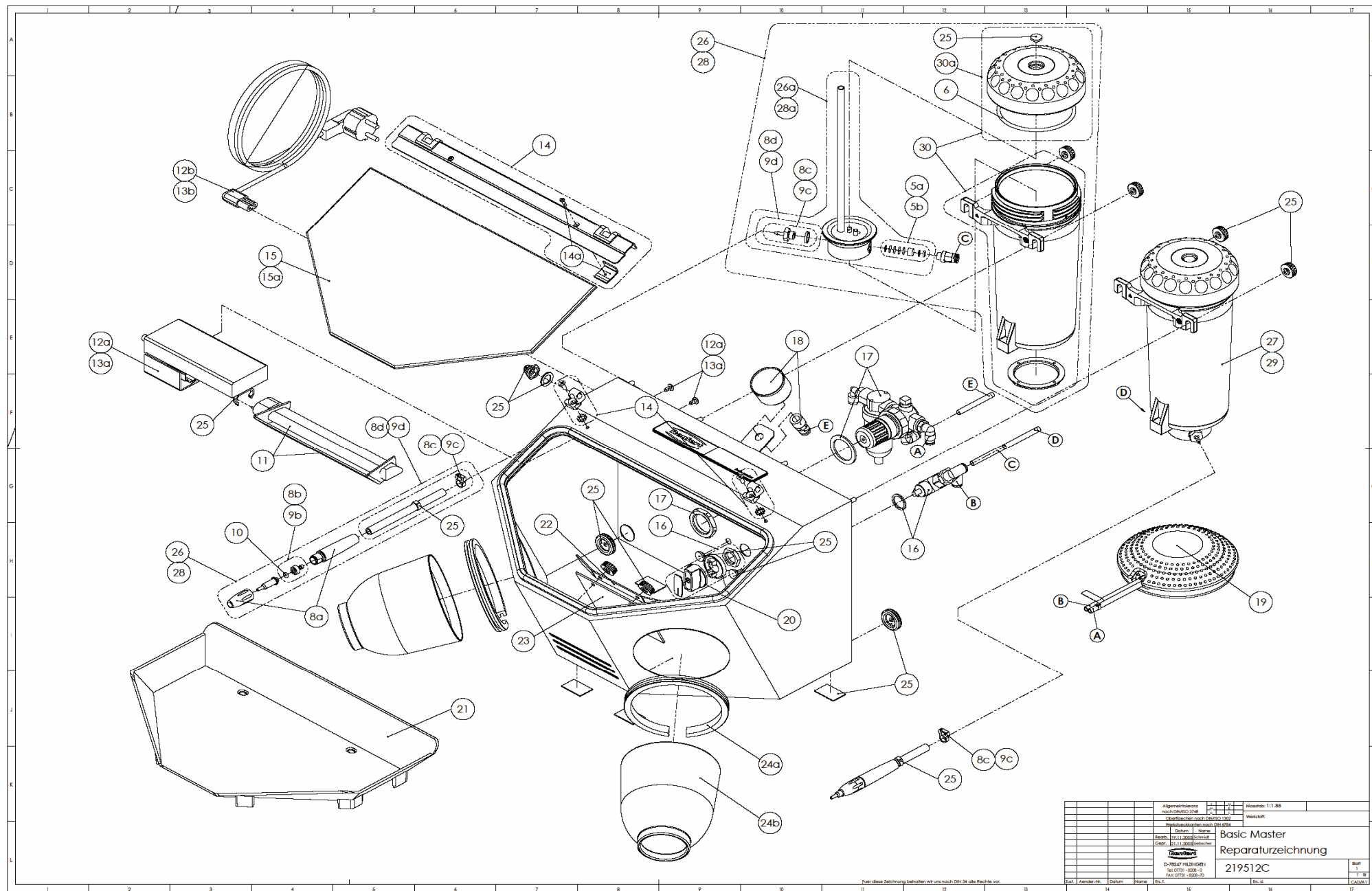

Allgemeinreferenz		27		Assembld. 1:1-85
Namen		28		Werkstoff
Abgabedatum nach DIN 50073				
Werkstoffbezeichnung nach DIN 50074				
Name				
Stand				
Geogr.				
Lithograph				
D-79647 HLZU/GERH				
Tel 07731 - 6338 - 0				
Fax 07731 - 6338 - 30				
Blatt	219512C			Blatt
				1
				1
				1
				1
				1
				1

Für diese Zeichnung behalten wir uns nach DIN 24 alle Rechte vor.